

# Installation Guide

## Pressure Control

### Type KP 15A

060R9752

060R9752

#### Refrigerants

R717, HCFC and non-flammable HFC

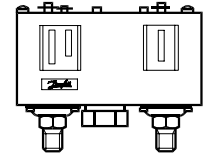

#### Ambient temperatures / Mounting requirements

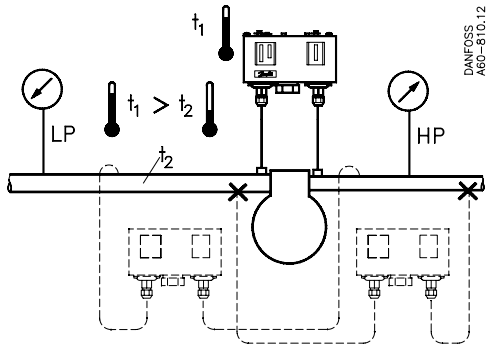

$t_1$  min.: -40 °F (-40 °C)  
 $t_1$  max.: 65 °C (149 °F)

**CAUTION:**  
 Do not mount the control in a position where dirt, sediment or oil will affect the operation of the control.

#### Test pressure (P<sub>test</sub>)

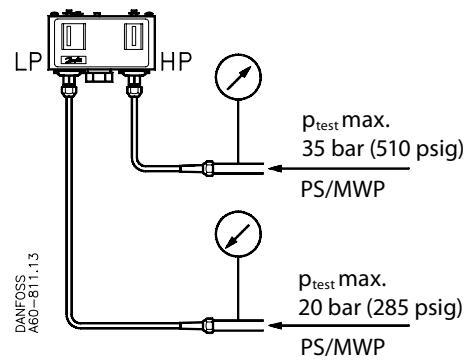

#### Connections

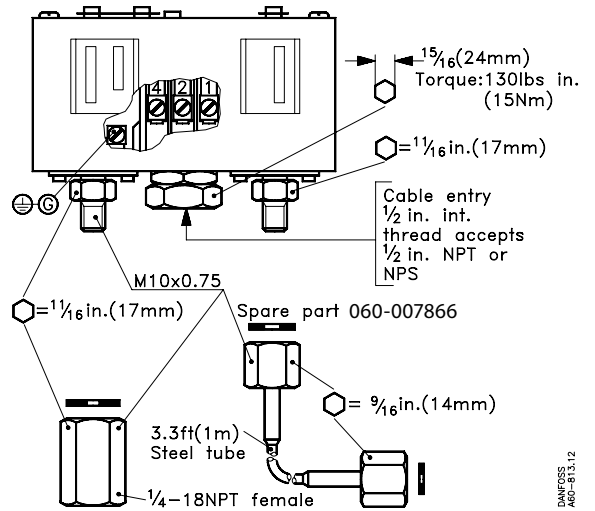

#### Cutting ring

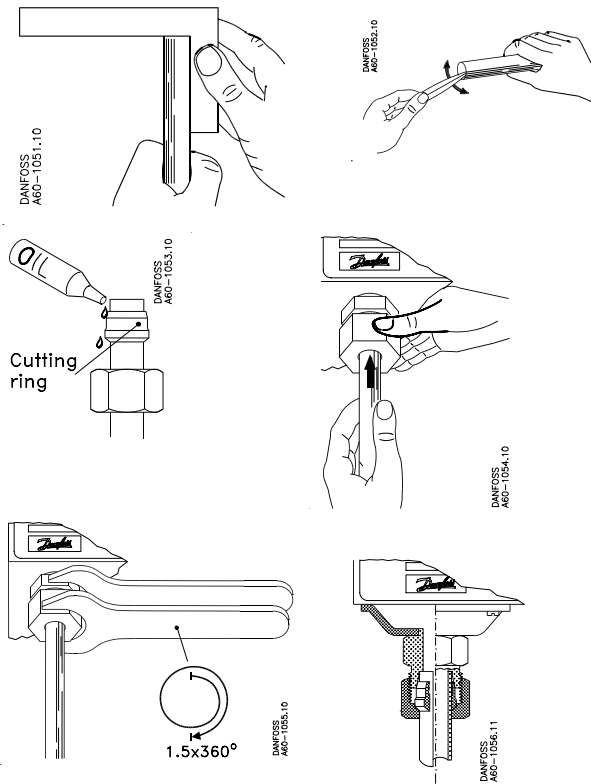

#### Mounting

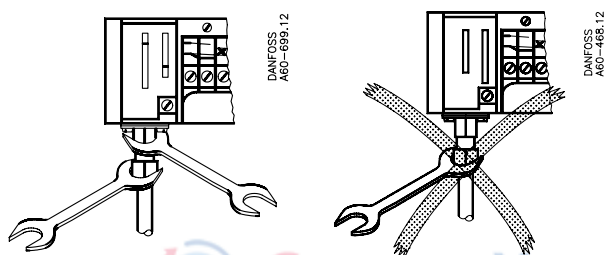

## Enclosure

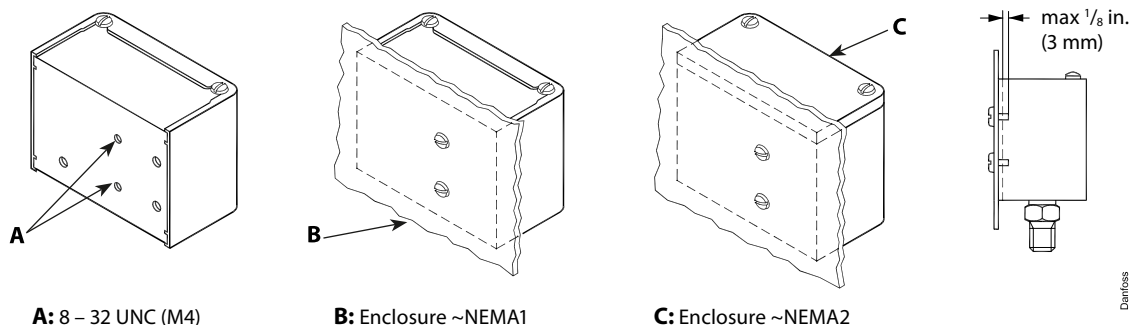

Danfoss  
61C406; 18 FW

### CAUTION:

The mounting panel must be plane to avoid damage of control.



### CAUTION:

Disconnect power supply before wiring connections are made or service to avoid possible electrical shock or damage to equipment. Do never touch live parts with your fingers or with any tool.

## Wiring

All wiring should conform to the National Electrical Code and local regulations.

### SPDT

#### Controls with low pressure (LP) signal

#### Terminal block

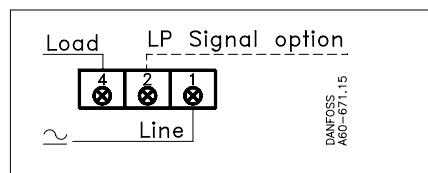

### CAUTION:

Use terminal screws furnished in the contact block.  
Use tightening torque 20 lb. in (2.3 Nm).  
Use copper wire only.

#### Low pressure (LP) side:

A-C close on LP rise  
A-C open on LP drop

#### High pressure (HP) side.

A-C open on HP rise  
A-C close on HP drop

#### LP signal option:

A-B close on LP drop

See label for current wiring inside cover

#### Controls with low pressure (LP) and high pressure (HP) signal

#### Terminal block

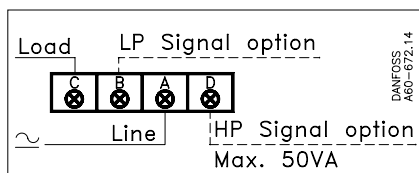

### CAUTION:

Use terminal screws furnished in the contact block.  
Use tightening torque 20 lb. in (2.3 Nm).  
Use copper wire only.

#### Low pressure (LP) side:

A-C close on LP rise  
A-C open on LP drop

#### High pressure (HP) side.

A-C open on HP rise  
A-C close on HP drop

#### LP signal option:

A-B close on LP drop

#### HP signal option:

A-D close on HP rise

#### Contact load ratings

120 V a.c.	16 FLA, 96 LRA
240 V a.c.	8 FLA, 48 LRA
240 V d.c.	12 W pilot duty

See label inside cover

## Function

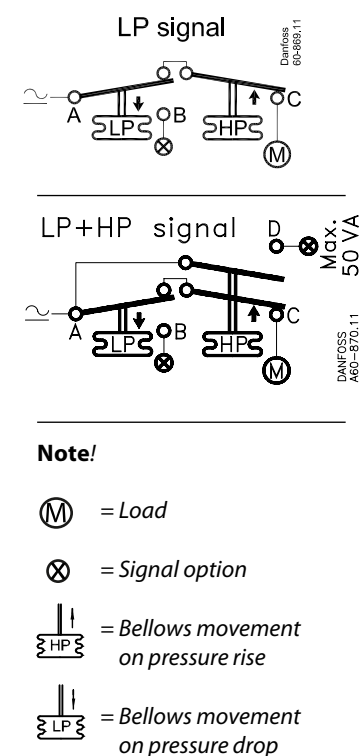

### Manual tripping

(Electrical contacts/wiring test)

#### LP side

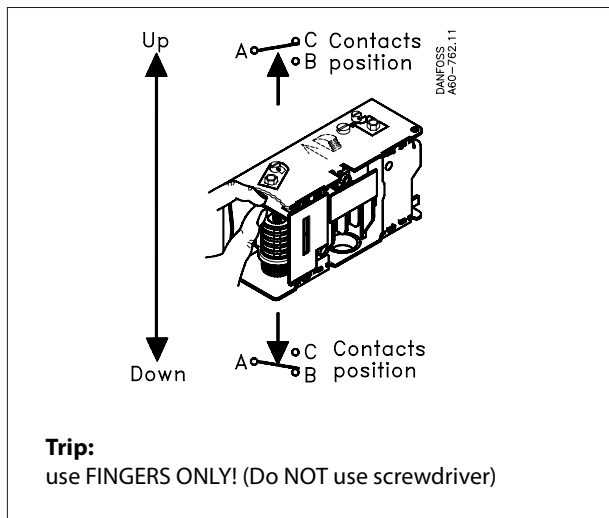

**Trip:**  
use FINGERS ONLY! (Do NOT use screwdriver)

#### HP side

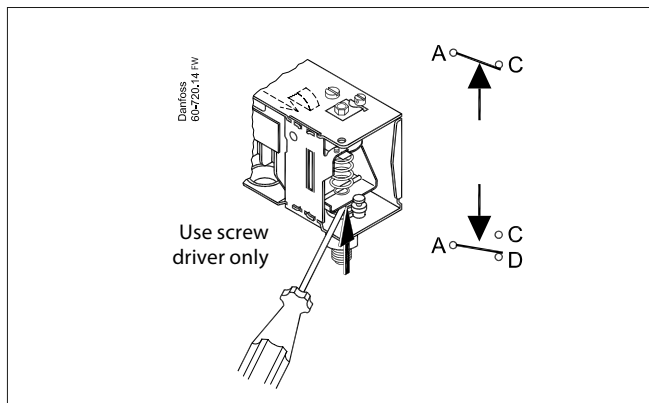

**Note:**  
On controls with LP and/or HP man. reset, push corresponding LP and/or HP man. reset knob during tripping.

### Manual reset

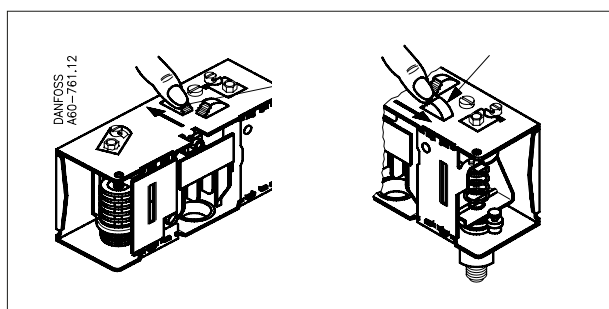

To resume control operation after safety cut-out, push man. reset knob as indicated.

**Note:**  
LP man. reset is possible only after system pressure has risen above cut-in value.  
HP man. reset is possible only after system pressure has dropped below cut-out value.

### Convertible reset

Insert a screwdriver into the slot on the lock disc and turn it to desired reset configuration. Do not turn the screw on the lock disc as it may damage the convertible reset mechanism.

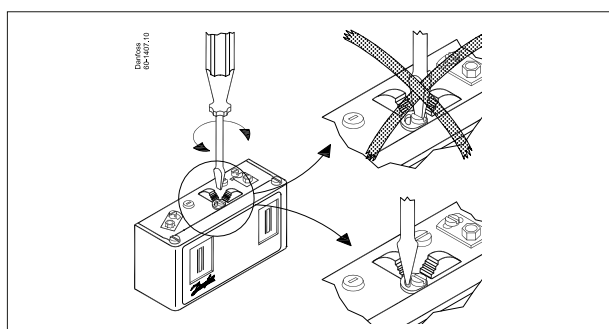

### Reset options

LP man.	LP auto.	LP auto.	LP man.
HP man.	HP man.	HP auto.	HP auto.

**Note:**  
Do not select automatic reset if safety of the system requires manual reset.

**Note:**  
Selected reset configuration may be protected against unauthorized actions applying a seal.

### Adjustment spindle(s) location

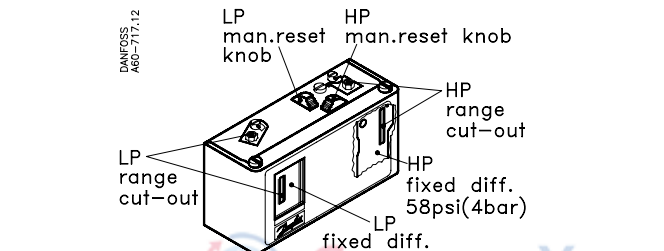
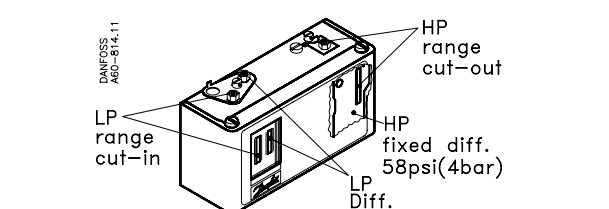

## Setting

### Low pressure (LP) side setting

KP 15A with LP auto. reset only

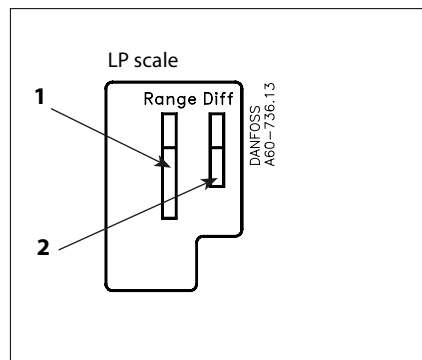

1. Adjust range spindle to desired CUT-IN value.
2. Adjust differential spindle to desired DIFFERENTIAL (DIFF.) value.

CUT-IN minus DIFFERENTIAL equals CUT-OUT

Example:

$$\begin{array}{rcl} \text{CUT-IN} & - & \text{DIFF.} = \text{CUT-OUT} \\ 30 \text{ psig} & - & 10 \text{ psi} = 20 \text{ psig} \\ (2.1 \text{ bar}) & (0.7 \text{ bar}) & (1.4 \text{ bar}) \end{array}$$

KP 15A with LP man. reset only

KP 15A with convertible LP auto./man. reset

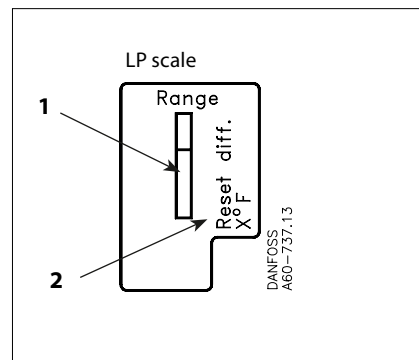

1. Adjust range spindle to desired CUT-IN value.
2. DIFFERENTIAL (DIFF.) is fixed. Value printed on scale plate.

CUT-IN equals CUT-OUT plus DIFFERENTIAL

Example:

$$\begin{array}{rcl} \text{CUT-OUT} + \text{DIFF.} & = & \text{CUT-IN} \\ 12 \text{ psig} + 10 \text{ psi} & = & 22 \text{ psig} \\ (0.8 \text{ bar}) (0.7 \text{ bar}) & & (1.5 \text{ bar}) \end{array}$$

### High pressure (HP) side setting

KP 15 A with HP auto./man. reset

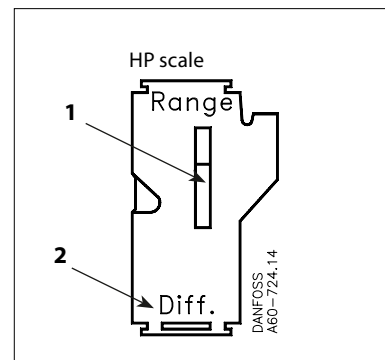

1. Adjust range spindle to desired CUT-OUT value.
2. DIFFERENTIAL (DIFF.) is fixed. Value printed on scale plate.

CUT-OUT minus DIFFERENTIAL equals CUT-IN

Example:

$$\begin{array}{rcl} \text{CUT-OUT} - \text{DIFF.} & = & \text{CUT-IN} \\ 203 \text{ psig} - 58 \text{ psi} & = & 145 \text{ psig} \\ (14 \text{ bar}) (4 \text{ bar}) & & (10 \text{ bar}) \end{array}$$

## Adjustment

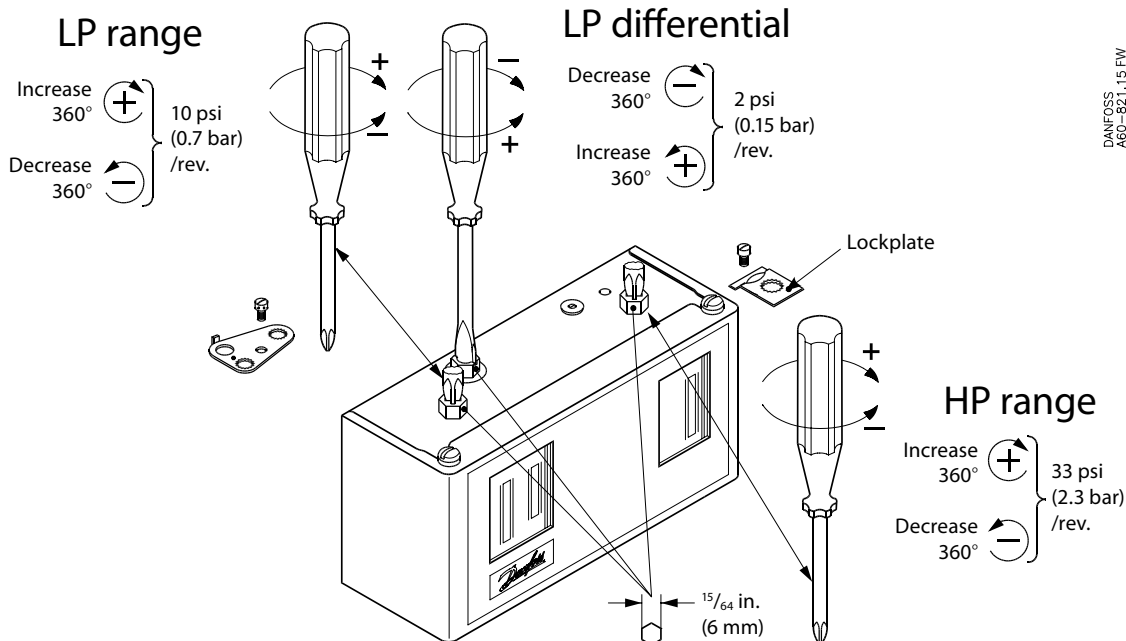

**Note:**  
Remove lockplate before adjustment.  
Replace lockplate after adjustment (if desired).